

WORLD MARKET®

Assembly Instructions

Langley Large Storage Cabinet

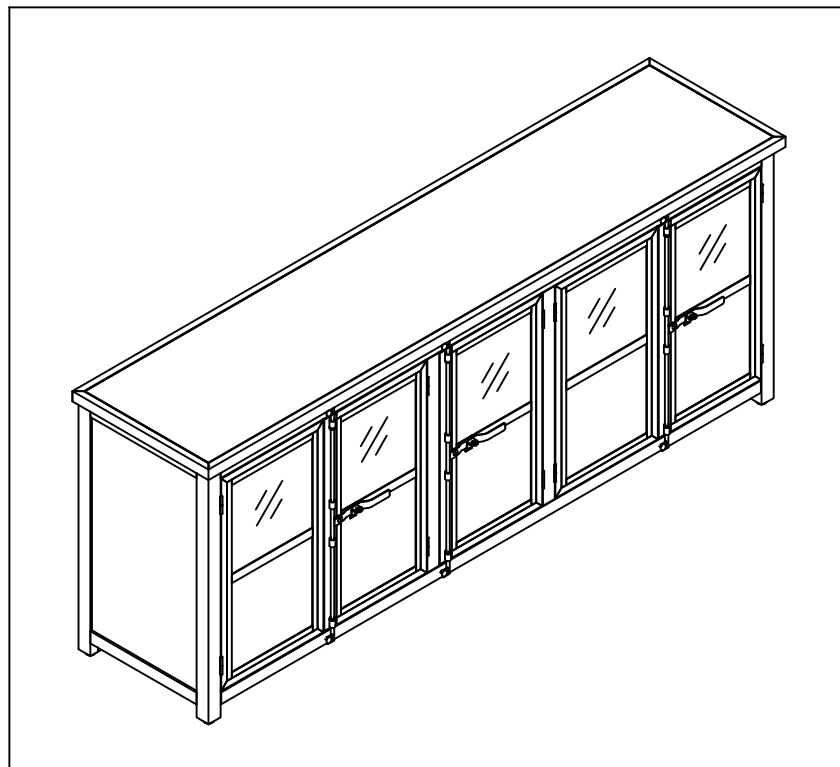





SKU - 526593



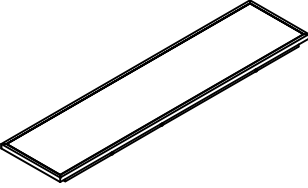
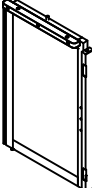
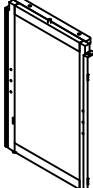
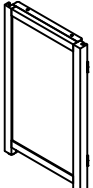
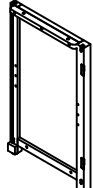



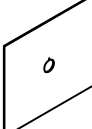
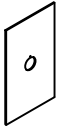
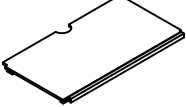
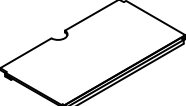
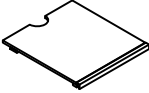
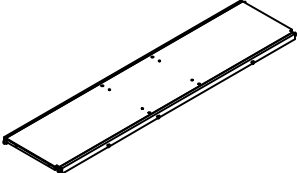



THANK YOU FOR PURCHASING OUR QUALITY PRODUCT. IF YOU HAVE ANY QUESTIONS PERTAINING TO THE ASSEMBLY OF THIS FURNITURE PIECE, PLEASE CONTACT YOUR NEAREST WORLD MARKET STORE, OR CALL OUR TOLL FREE NUMBER 877-967-5362 FOR ASSISTANCE.

NOT FOR COMMERCIAL USE.

Part List

					
A : Top Frame - 1 pc	B1 : Left Divider Frame - 1 pc	B2 : Right Divider Frame - 1 pc	C1 : Left Side Frame - 1 pc	C2 : Right Side Frame - 1 pc	
					
D1 : Left Door - 2 pcs	D2 : Right Door - 2 pcs	D3 : Middle Door - 1 pc	E1 : Back Panel 1 - 2 pcs	E2 : Back Panel 2 - 1 pc	F1 : Left Shelf Frame - 1 pc
					
F2 : Right Shelf Frame - 1 pc	F3 : Middle Shelf Frame - 1 pc	G : Bottom Frame - 1 pc	H : Back Lid - 3 pcs	I : Center Leg - 3 pcs	

Hardware List

Label	Picture	Description	Size	Qty
H-1		Allen Bolt	Ø6x40 mm	8
H-2		Allen Bolt	Ø6x55 mm	8
H-3		Lock Washer	Ø6xØ10.5xT2 mm	16
H-4		Flat Washer	Ø6xØ16xT2 mm	16
H-5		Shelf Pin		12
H-6		Connector Bolt	Ø6x10 mm	3
H-7		Allen Bolt	Ø6x13 mm	3
H-8		Flat Washer	Ø10xØ20xT2 mm	3
H-9		Anti-Tip Kit		1

Tool List

Label	Picture	Description	Size	Qty
T-1		Allen Key	4 mm	2
T-2		Triangle		1
T-3		Straight Wood Bar		1
T-4		Phillips Screwdriver (Not provided)		1

Assembly Preparation

Before Beginning :

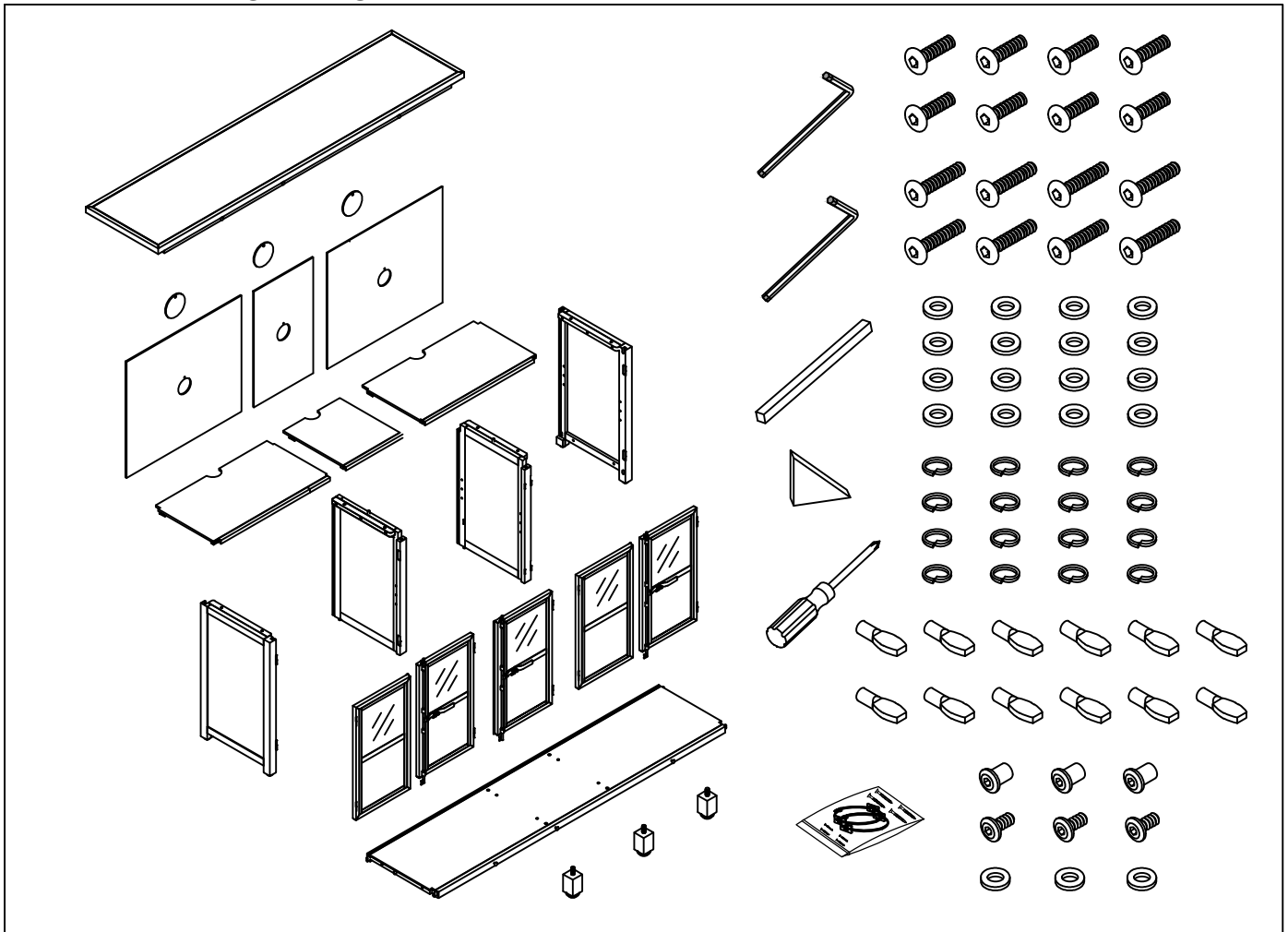

● Unpack all hardware bags and components to ensure you have all parts.



● Read instructions, cover to cover.



● Have 2 adults on hand for assembly.



● Do not assemble on flooring or carpet.



● Assemble on a clean non-marring surface (packing foam).



● Save all packaging until finished.



● In case of missing parts, please contact your nearest World Market store or our customer service call center 877-967-5362.

Assembly Steps

Step 1

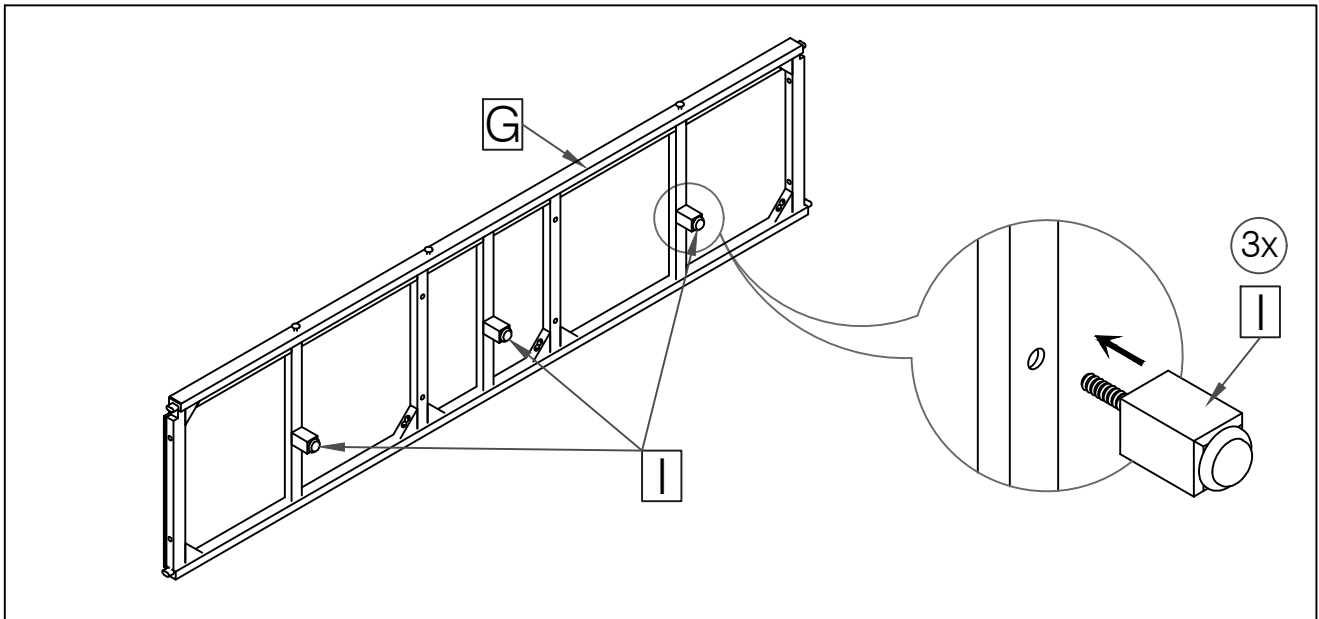

On a non-marring surface, position and secure Center Legs (I) to Bottom Frame (G) by using screw on Center Legs (I).

Step 2

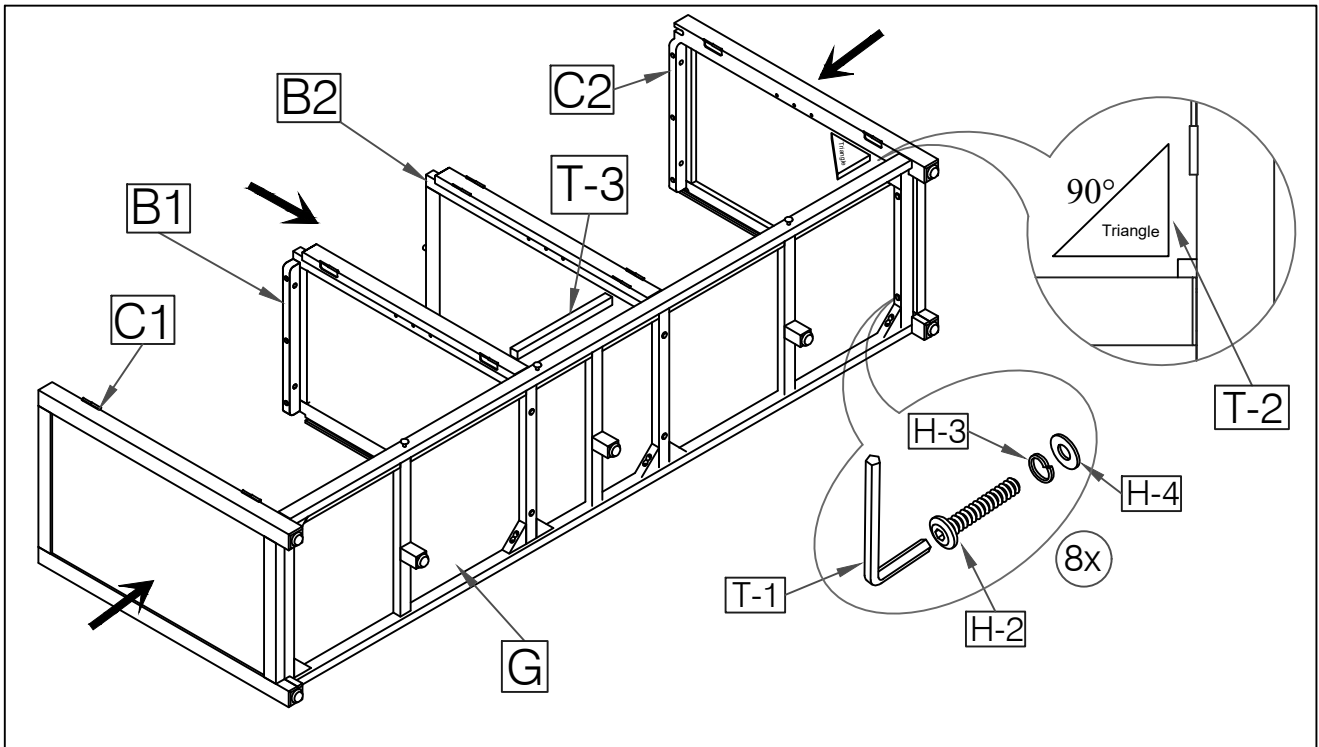

On a non-marring surface, position and secure Left Side Frame (C1), Right Side Frame (C2), Left Divider Frame (B1) and Right Divider Frame (B2) to Bottom Frame (G) with Flat Washers (H-4), Lock Washers (H-3) and Long Allen Bolts (H-2) by using the Allen Key (T-1). Then, use the Straight Wood Bar (T-3) as a tool to check the distance between dividers. Last, use the provided 90° Triangle (T-2) and adjust the corners to make sure the Side Frames and Dividers are square. Fully tighten Allen Bolts.

Step 3

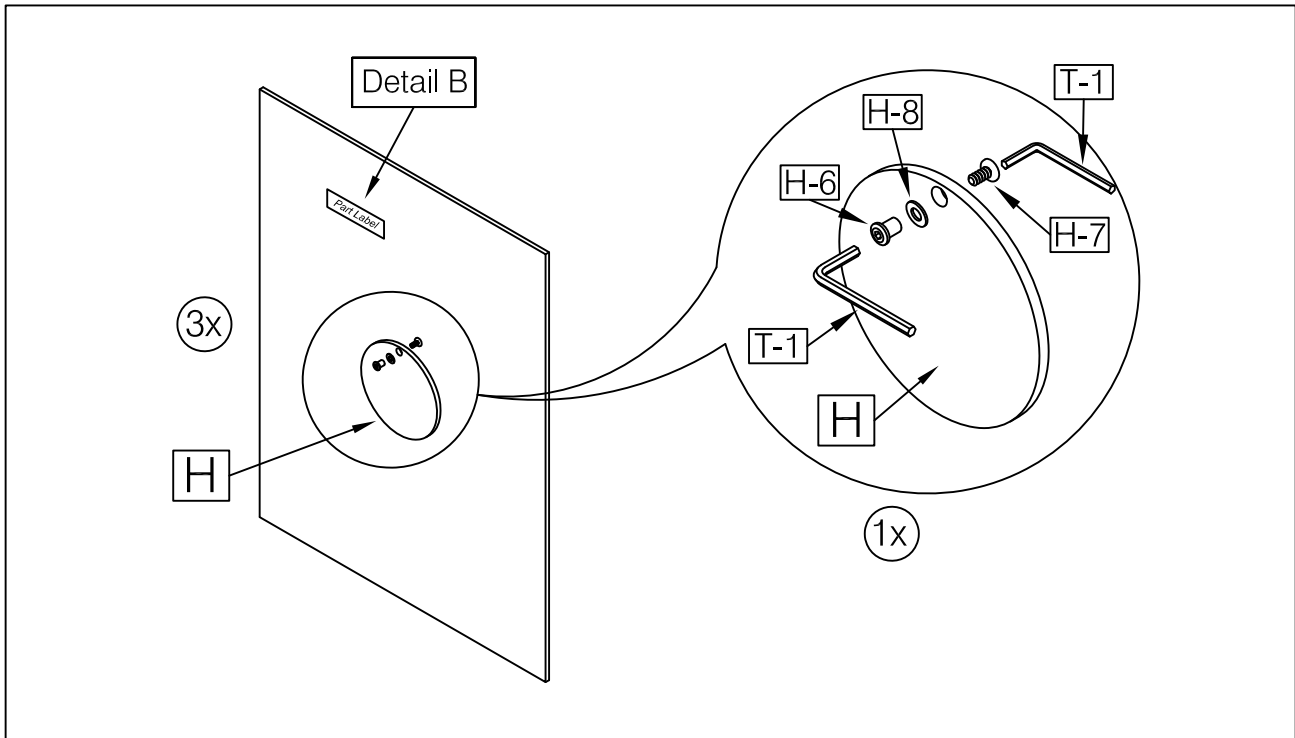

Position and secure Back Lids (H) to Back Panels 1 (E1) and Back panel 2 (E2) with Connector Bolts (H-6), Flat Washers (H-8) and Small Allen Bolts (H-7) by using the Allen Keys (T-1). Do not over tighten Allen Bolts.

Step 4

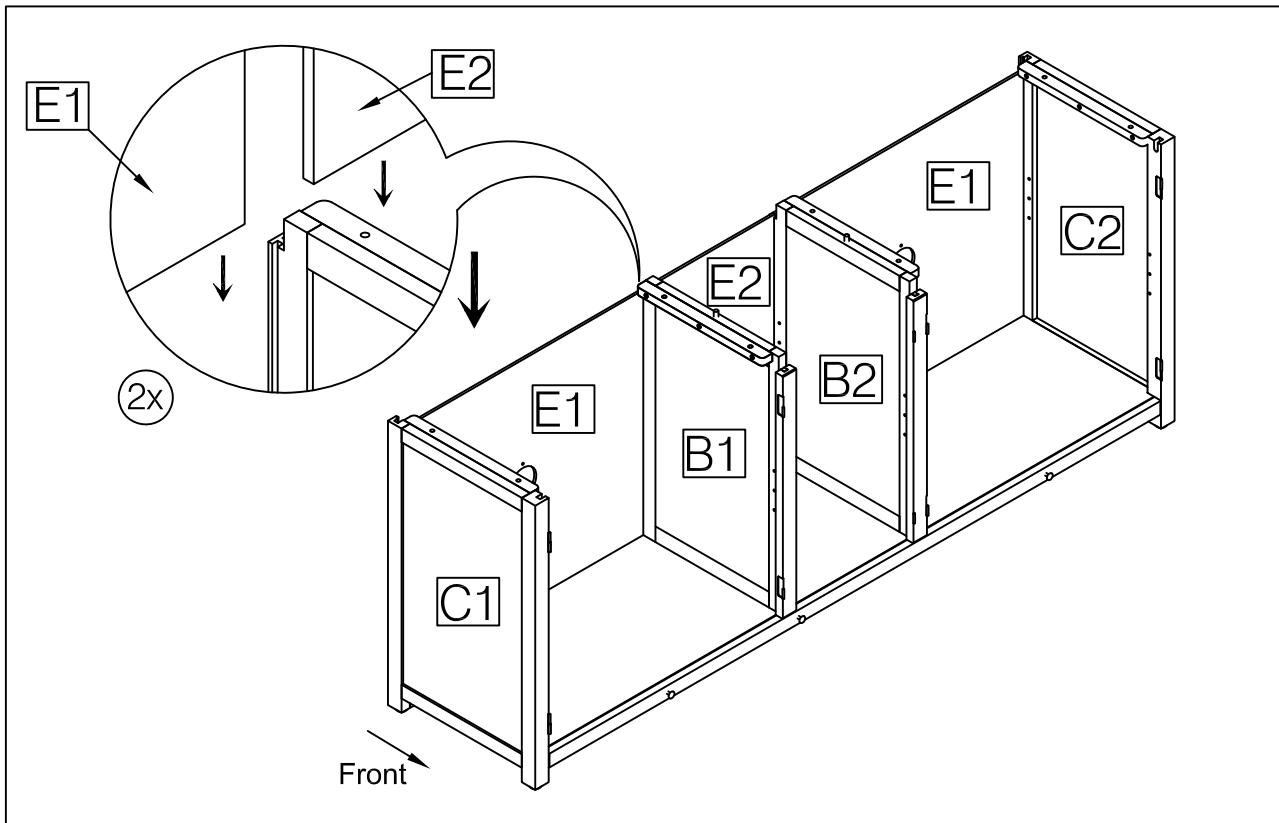

Turn assembled unit upright. Insert Back Panels (E1) into Left Side Frame (C1) and Left Divider Frame (B1) then Right Side Frame (C2) and Right Divider Frame (B2). Insert Back Panel (E2) into Left Divider Frame (E1) and Right Divider Frame (E2)

Step 5

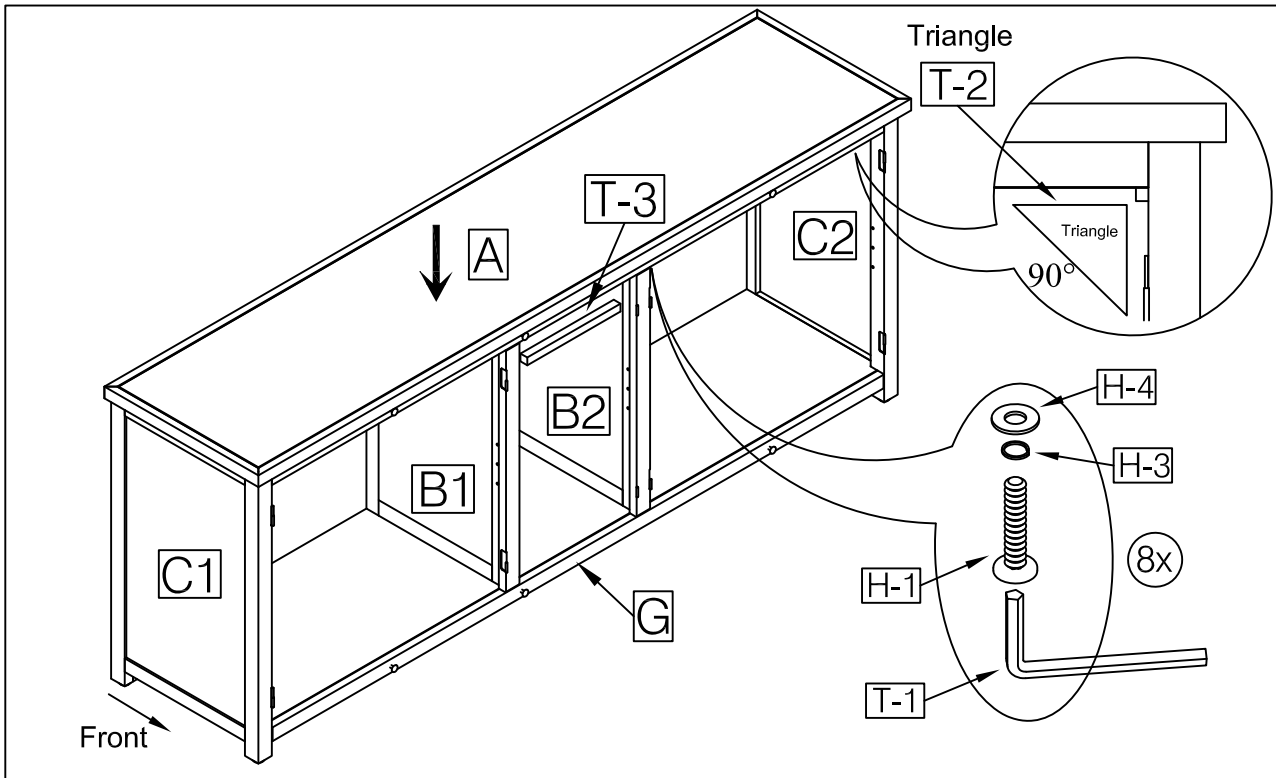

Position and secure Top Frame (A) to Side Frames (C1 & C2) and Divider Frame (B1 & B2) with Flat Washers (H-4), Lock Washers (H-3) and Short Allen Bolts (H-1) by using the Allen Key (T-1).

Then, use the Straight Wood Bar (T-3) as a tool to check the distance between dividers. Last, use the provided 90° Triangle (T-2) and adjust the corners to make sure the Storage Cabinet is square. Fully tighten Allen Bolts.

Step 6

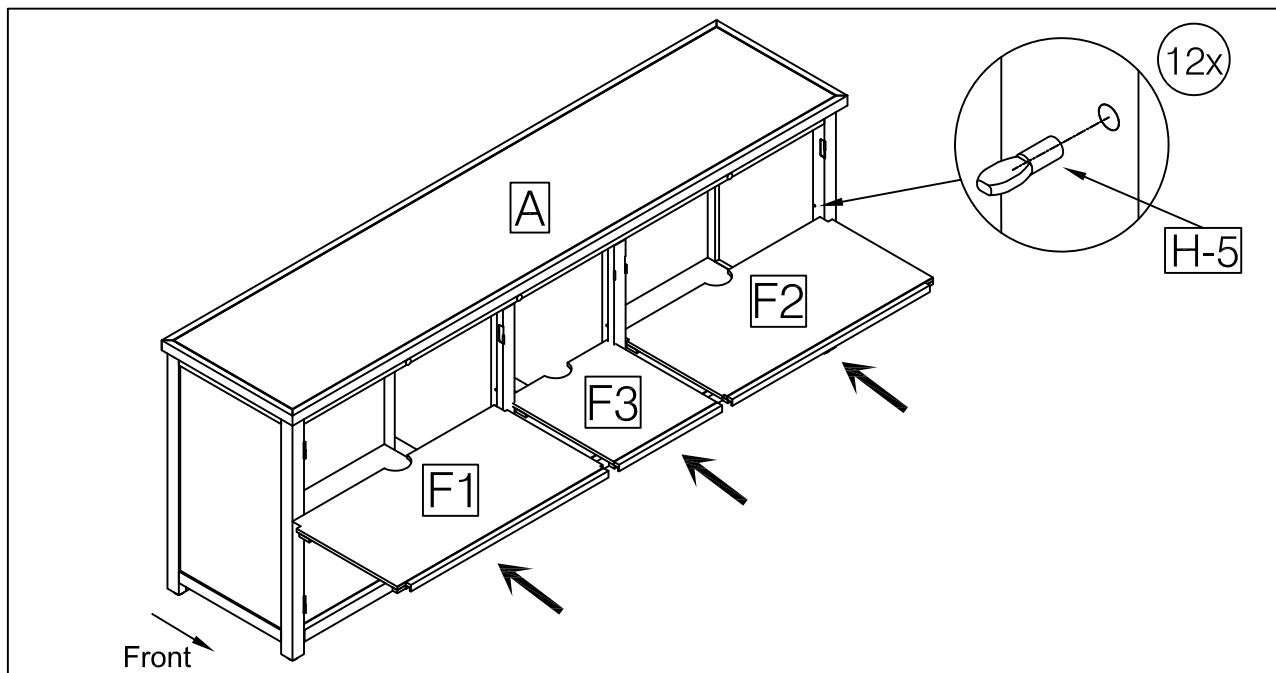

Insert Shelf Pins (H-5) into the pre-drilled holes at desired height location on the Side Frames (C1 & C2) and Divider Frame (B1 & B2). Place Shelf Frames (F1, F2 & F3) onto the Shelf Pins (H-5).

Step 7

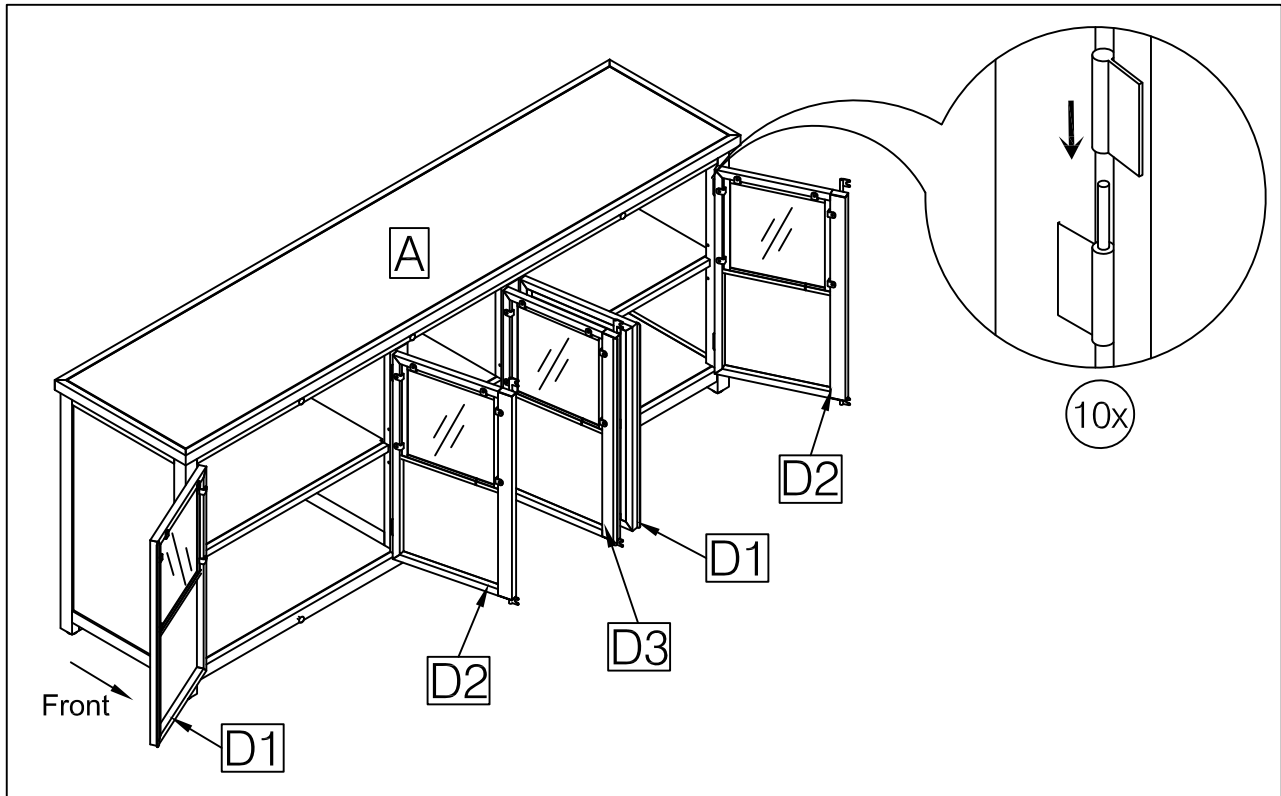

Position and secure Left Doors (D1), Right Doors (D2) and Middle Door (D3) to Side Frames (C1 & C2) and Divider Frames (B1 & B2) by inserting male hinges into female hinges, which are pre-installed.

Step 8

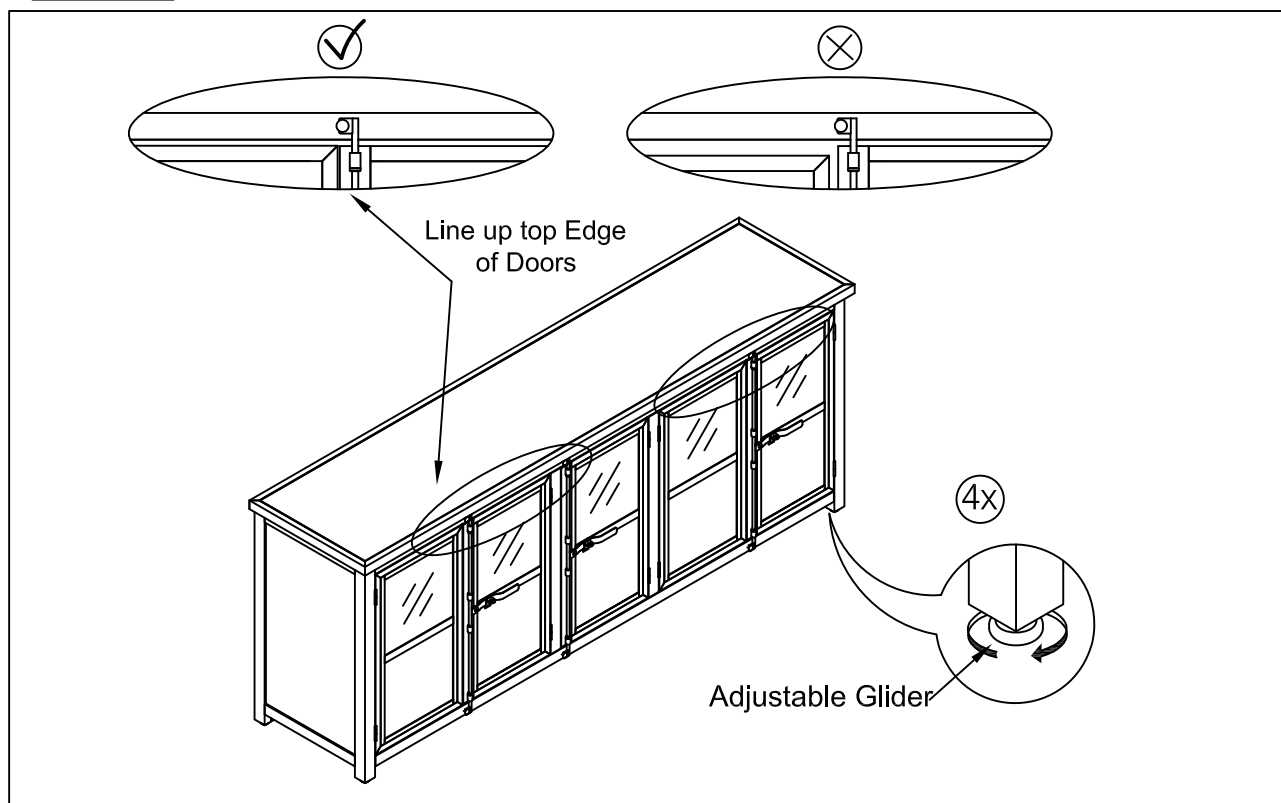

Check Cabinet front door alignment. Both doors should be evenly spaced at the top, as shown. If not, gently push or pull the upper right corner of the misaligned door side and observe the gap opening or closing. Adjust the corresponding leveler located at the bottom of each Cabinet Foot.

Step 9

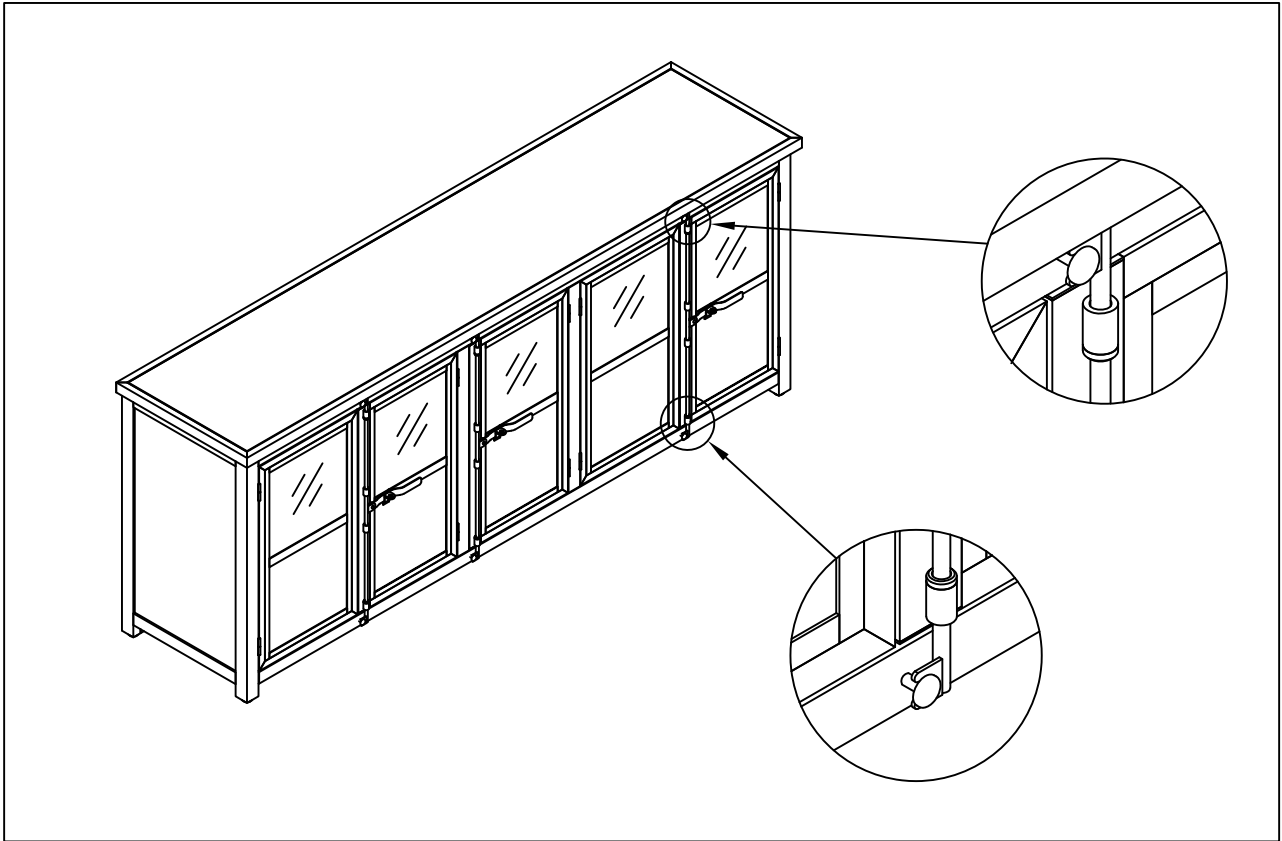

Step 10

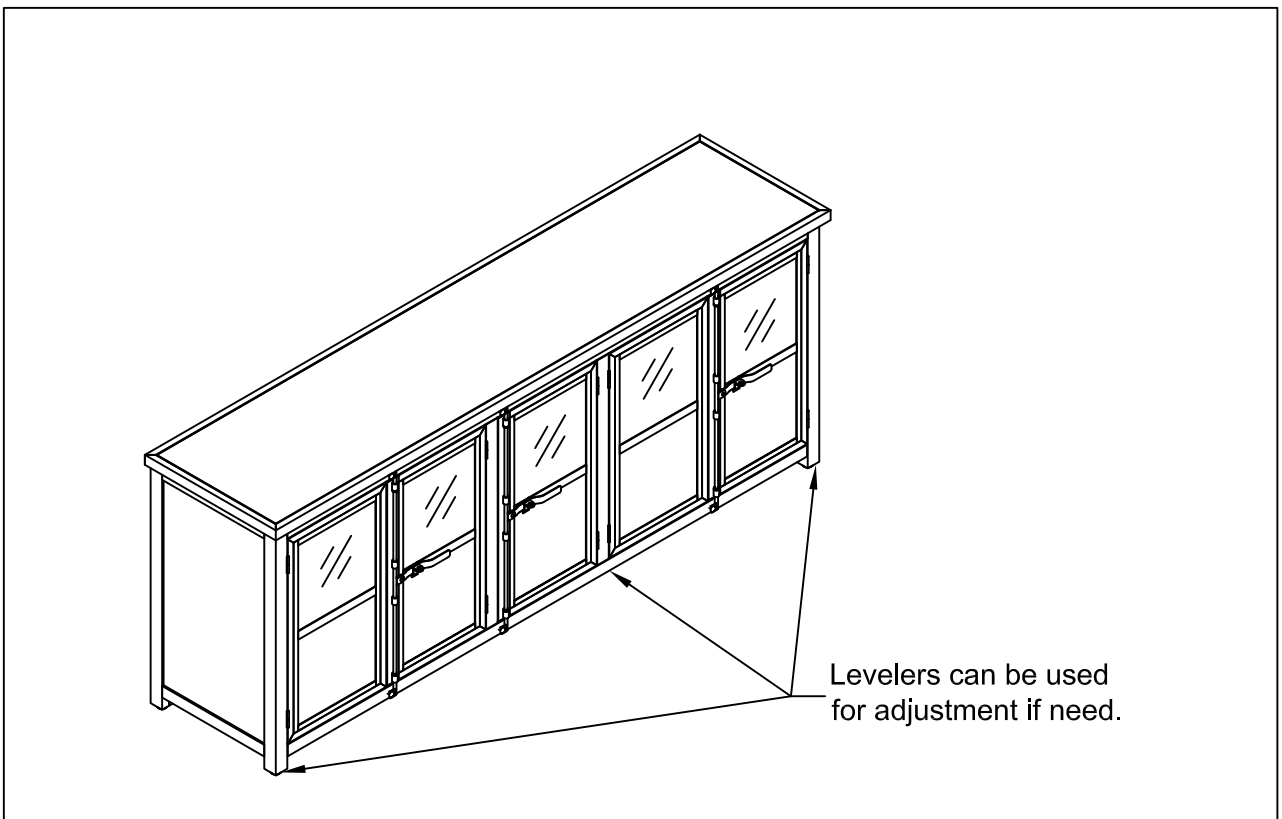

The Langley Large Storage Cabinet is assembled and ready for use.

Care & Maintenance



- Do not put hot items directly on furniture surface.

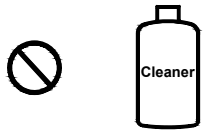

- Do not clean furniture with harsh cleansers or polish.

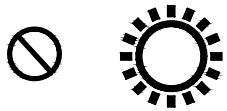

- Do not place furniture in direct sunlight.



- Do not place furniture near heating or cooling vents.



- Do not write on furniture without a padded barrier to protect the surface.



- Do not place furniture outside. For indoor use only.



- Not for commercial use. For residential use only.



- Dust and pick-up spills using a clean, non-colored, lint-free cloth.

Anti-Tip Measures

WARNING - Children may be injured by tipping furniture and the use of the Anti-Tip Kit is highly recommended.

This Anti-Tip Kit (H-9) is only a precaution. It is not a substitute for proper adult supervision. Manufacturer or retailer assumes no liability for improper installation or excess loads placed on screws, brackets, or straps.

When properly installed, this restraint provides protection against unexpected tipping of furniture.

This Anti-Tip Kit **MUST** be installed into a wall stud using the proper mounting hardware. (Position of Anti-tip Kit on product depends on wall stud locations).

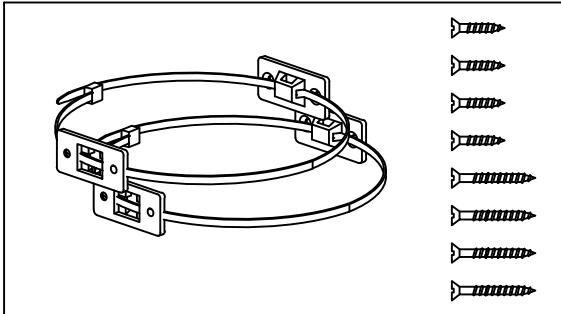

Anti-Tip kit contents

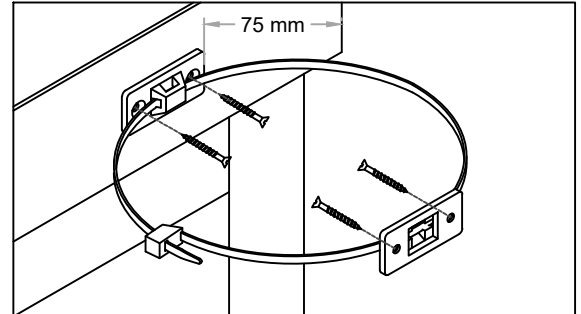

Anti-Tip kit installation

⚠ WARNING	
	<p>Children have died from furniture tipover.</p> <p>To reduce the risk of furniture tipover:</p> <ul style="list-style-type: none"> • ALWAYS install tipover restraint provided. • For use with televisions weighing 100lbs (45kg) or less. Use with heavier televisions may result in instability causing tip-over resulting in death or serious injury. • NEVER allow children to stand, climb or hang on drawers, doors, or shelves. • NEVER open more than one drawer at a time. • Place heaviest items in the lowest drawers. <p><i>This is a permanent label. Do not remove!</i></p>

